

## 52CM BLACK UNDER MOUNT RANGEHOOD



- Huge 750 m<sup>3</sup>/h Airflow
- Bright LED Strip Light
- Premium Black Glass Fascia & Touch Control

### Powerful Black Glass Under Mount Rangehood - 520mm

#### Features

- Sleek Inbuilt Undermount Design
- Touch Controls & Digital Display
- 210w Large Barrel Motor
- Bright 1.5W LED Strip Light
- Three Speed Fan
- Premium Black Glass Fascia
- 750m<sup>3</sup>/h Air Flow
- Designer Hinged Baffle Plate
- Dishwashable Filter
- 150mm Diameter Outlet

#### Dimensions (WxDxH):

520mm x 280mm x 258mm  
(Cutout: 490 x 250)

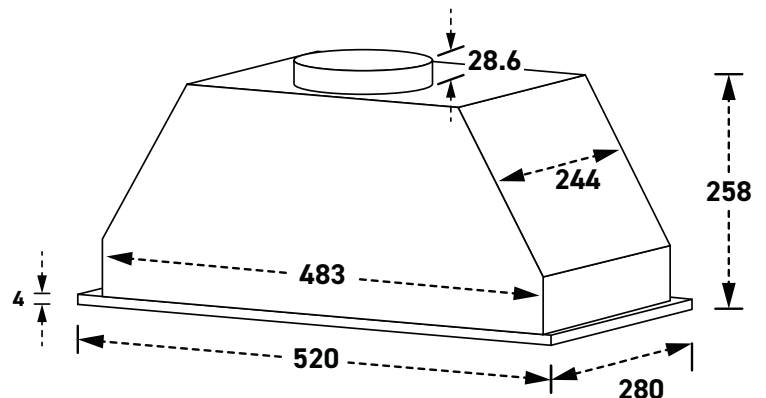

Charcoal filters are sold separately  
(required in re-circulating use)

## 60CM GAS ON GLASS COOKTOP

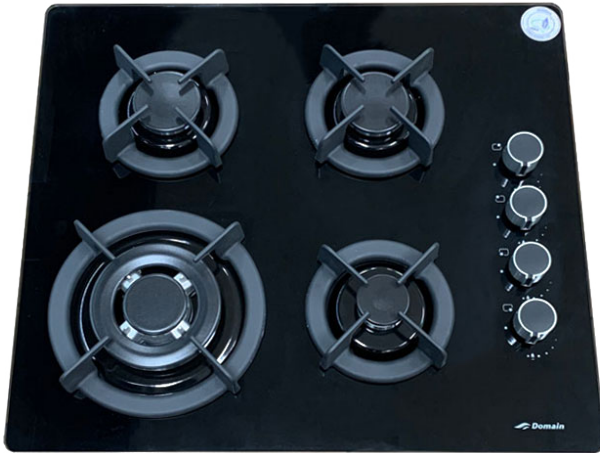

- Cast Iron Trivets
- Powerful Triple Ring Wok Burner
- Stylish Black Glass Base

### Gas on Glass Cooktop + Wok Burner + FFD - 600mm

#### Features

- 4 Burners
- Stylish Tempered Glass Base
- Flame Failure Device
- Triple Ring Wok Burner
- Cast Iron Trivets  
Italian Burners
- Electric Ignition Under Knob
- Side Knob Controls
- Flat Glass Design for Ease of Cleaning
- AGA Approved
- Appliance Fitted with 10amp  
3 Pin Plug

LPG jets available on request.

#### Technical Information

Triple Ring Wok Burner  
12.3 Mj/h

Rapid Burner  
11.0 Mj/h

Semi Rapid Burner  
6.5 Mj/h

Auxiliary Burner  
3.8 Mj/h

#### Dimensions (WxDxH):

External : 600mm x 520mm x 60mm

Cut Out : 553mm x 473mm

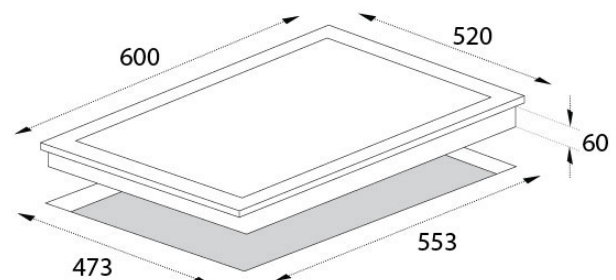

## 60CM BLACK GLASS FAN FORCED ELECTRIC OVEN



- Cool Touch Triple Glazed Glass Door
- 75 Litre Internal Cavity Capacity
- Digital LED Display

## 5 Function Black Glass Fan Forced Electric Oven - 595mm

### Features

- 5 Functions
- Tripled Glazed Glass Door
- Huge 75 Litre Capacity
- Closed Door Grill
- Easily Removable Door
- Cavity Cooling System
- Black Stainless Steel Handle
- Easy Use Analogue Controls
- Digital LED Display
- Black Aluminium Knobs
- 24 Hour Digital Timer
- 10 Amp Plug - Plugs Into a Standard Powerpoint

### Dimensions :

A - 595	D - 560
B - 595	E - 570
C - 575	F - 100
	G - 600

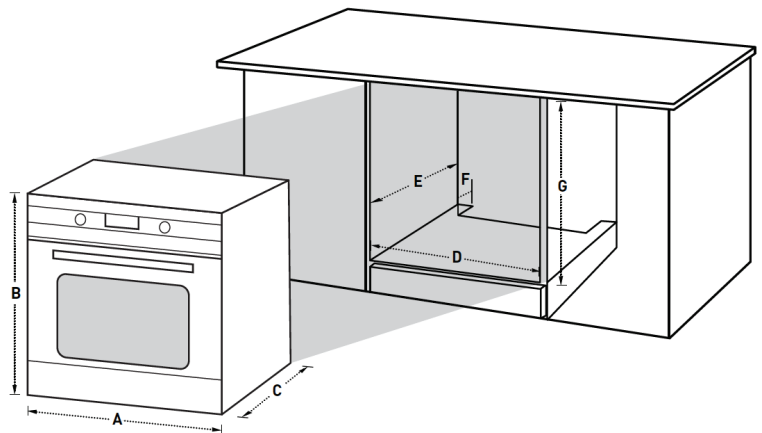

### Functions

- Light
- Defrost
- Fan Forced
- Grill Element
- Grill Element and Fan

## 60CM BLACK STAINLESS STEEL DISHWASHER

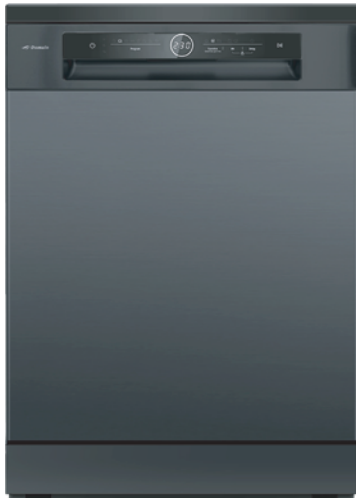

- Premium Top Cutlery Tray
- Adjustable Height Racking
- Touch Control w. 24h delay
- Fits Full 15 Place Settings

### 15 Place Setting Black Stainless Steel Dishwasher - 598mm

#### Features

- Electronic Freestanding Dishwasher
- 15 Standard Place Settings
- Extra Dry Function
- 8 Washing Programs
- Auto Open for Improved Drying
- Top Cutlery Tray
- Large Touch Control LED Display
- Height Adjustable Upper Basket
- Dualzone Wash (Half Load) Function (Upper or Lower)
- Stainless Steel Interior Tub
- Adjustable Automatic Rinse Agent Dispenser
- Automatic Detergent Dispenser
- Delay Start (1 - 24hrs)
- Advanced Filtering System
- Collapsible Plate Rack
- Child Safety Lock
- Super Quiet Operation
- Removable Top For Built-in Installation

#### Efficiency

- 5 Star Water Rating
- 4 Star Energy Rating
- WELS Approved
- MEPS Approved

#### Dimensions (WxDxH) :

598mm x 600mm x 845mm

