

60CM SLIM FIXED MOUNT RANGEHOOD - 80MM TALL



- Super Slimline Design, Only 80mm Tall!
- Strong 440m³/h Airflow
- Bright 2W LED Lamp
- Dishwashable Filters

Slimline Stainless Steel Fixed Mount Rangehood - 600mm

Features

- Fixed Rangehood
- Stainless Steel Fascia
- Glass Visor
- Bright Central 2W LED Lamp
- Three Speeds
- Twin 100W Motors
- Ducted or Recirculating Mode
- Strong 440m³/hr Air Flow
- Push Button Controls
- Three Layer Aluminium Filters
- Dishwashable Filters
- 120mm Diameter Outlet

Dimensions (WxDxH):

600mm x 500mm x 80mm

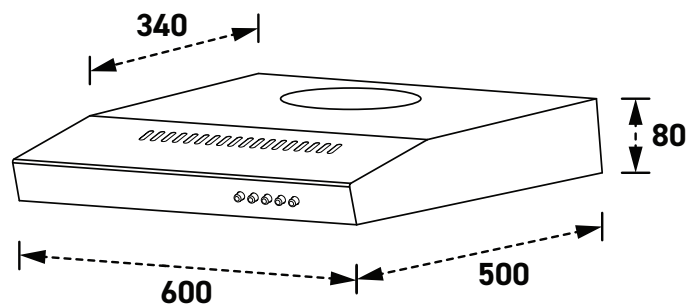

*Charcoal filters are sold separately
(required in re-circulating use)